

Turntable Series Stretch Wrappers

RAPTOR[®]

1525CN *Automatic*



NEW!



*Simplified film
threading with
improved operator
ergonomics*

Octo-Thread

*Raptor 1525CN with standard
infeed, turntable and exit
conveyor (shown without
standard guarding for clarity).*

*Conveyor-Ready Raptor 1525CR
also available.*

- Wraps up to 45 loads per hour
- 4,000 pound capacity
- Heavy duty construction
- Pre-stretches film up to 300%
- Ring and pinion drive
- Allen-Bradley PLC with operator interface
- Octo-thread carriage allows ease of film threading
- Strain gauge film delivery control
- 3-1/2" dia. conveyor rollers on 3-3/4" centers

TW Muller

Raptor 1525CN

Automatic Turntable Stretch Wrapper

Specifications

Standard configuration listed below. Please contact your sales representative for other available configurations.

Performance

| | |
|---------------------|------------------------------|
| Loads per hour | Up to 35 |
| Rotation speed | Adjustable up to 16 rpm |
| Maximum load size | 50" x 54" x 80" H (72" dia.) |
| Minimum load size | 36" x 36" x 28" H |
| Conveyor elevation | 20" |
| Maximum load weight | 4,000 pounds |

Film Delivery System

| | |
|-------------------|--|
| Film capacity | 20" roll width x 10" dia. |
| Pre-stretch type | Strain gauge |
| Pre-stretch level | 250% (optional 100% to 300%) |
| Force control | Variable |
| Film threading | Octo-Thread design; W film threading pattern |
| Cut and seal | Controlled impulse cutter and heat sealer |

Controls

| | |
|-----------------------|--|
| Controller | Allen-Bradley PLC |
| Operator interface | Touch screen |
| Load height sensor | Photo eye |
| Wrap settings | Re-wrap function, overwrap and overlap adjustments |
| Wrap counters | Independent top and bottom |
| Cycle counters | Total cycle counter and resettable counter |
| Emergency stop | Mushroom head |
| Electrical disconnect | Lockable |
| Electrical enclosure | CSA approved |

Power Requirements

| | |
|-----------|---------------------------------|
| Voltage | 480 VAC, 30 amp, 3 phase, 60 Hz |
| Pneumatic | 80 psi, 3 CFM (clean, dry air) |

Turntable

| | |
|--------------------|--|
| Size | 76-1/2" dia. |
| Bearing type | ring gear |
| Drive system | Ring and pinion |
| Conveyor rollers | 3-1/2" dia. on 3-3/4" centers; every roller driven; rollers set in pillow block bearings |
| Transition rollers | Included |

Structure

| | |
|--------------------|---|
| Machine dimensions | 1525CN: 114" x 192" x 98" H 1525CR: 114" x 95-1/2" x 98" H |
| Machine weight | 1525CN: 5,675 pounds 1525CR: 3,250 pounds |
| Construction | Heavy duty, welded |
| Color | Dark bronze |

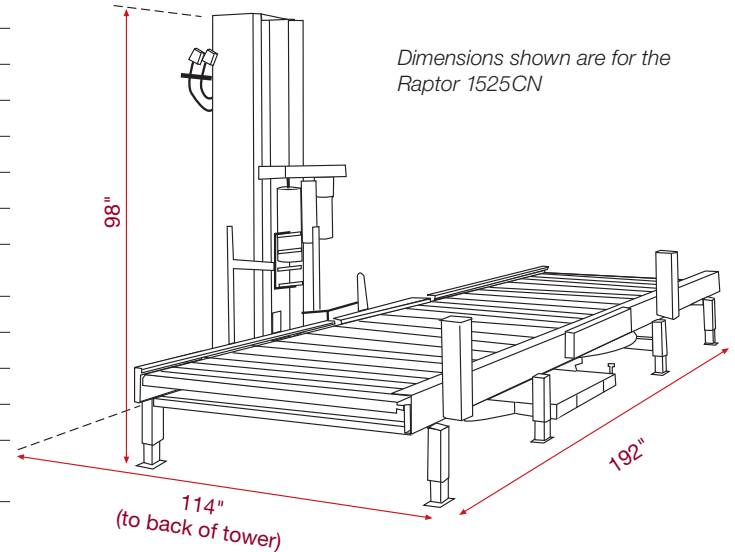

TW Muller